



"VX" - window/wall



- Axial fans for small, medium and large rooms
- For walls, ceilings, panels or windows
- 6 models, 3 sizes
- Manual and Automatic
- Reversible models
- Silent, slow moving shutters
- Exceeds Building Regulations requirements (including new Document F)

GENERAL

- for domestic/commercial use
- to exhaust air directly outside through windows walls, ceilings, panels and double glazed windows.
- for kitchens, larger bathrooms, offices, pubs, restaurants, shops, warehouses, etc
- all automatic models with slow moving, delay action shutters for silent opening and closing
- complete with wall rods
- automatic reversible models complete with 5 speed remote controller which also allows fan shutters to be left open for natural ventilation without security risk
- incorporate neon light indicator to show when fan energised
- easy to connect plug and socket
- outside grille protected against rain to IPX4

SPECIFICATION

- casings formed from high quality, impact resistant, white technopolymer with high mechanical strength
- motors of shaded pole type mounted on self lubricating, sealed for life bearings for long life and quiet running
- Impedance protected induction motor protected with thermal cut-out
- double insulated
- maximum ambient temperature 40°C

COMPLY WITH

- CEI61/28 - IEC342-1
- EC Low Voltage Directive 73/23-93/68
- EC Directive EMC89/336
- CE marked
- Keymark Approved

RANGE

- **VX15/6M**
6"/15cm cord
- **VX15/6A**
6"/15cm automatic
- **VX23/9M**
9"/23cm cord
- **VX23/9MR**
9"/23cm cord, reversible
- **VX23/9AR**
9"/23cm automatic, reversible
- **VX30/12AR**
12"/30cm automatic, reversible

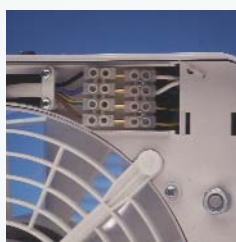

VX plug and socket for easy wiring

5 Speed Controller included with all reversible models



TYPICAL SPECIFICATION

Supply and install a VX23/9AR automatic, reversible window/wall fan as supplied by Vectaire Ltd, Lincoln Road, Cressex Business Park, High Wycombe, Bucks, HP12 3RH.

This fan is to be suitable for installation in domestic or commercial premises into solid or cavity walls, single or double glazed windows or in a ceiling.

It is to be operated by a remote 5 speed controller (included with the fan) which also allows reversibility and the fan shutters to be left open for natural ventilation. The shutters should be of the silent opening, slow moving type. It should have a quick-fit plug and socket for easy electrical connection and be double insulated.

The fan casing should be formed from high quality, impact resistant, white technopolymer with high mechanical strength and the motor be quiet running and of the shaded pole type mounted on self lubricating, sealed for life bearings for long protected with thermal cut-out.

Fan to comply with all current IEE, EC and Building Regulations requirements and be keymark approved.



Tel: +44(0)1494 522333
Fax: +44(0)1494 522337

Vectaire Ltd
Lincoln Road, Cressex Business Park
High Wycombe, Buckinghamshire, HP12 3RH

Email: sales@vectaire.co.uk
Web: www.vectaire.co.uk

TECHNICAL CHARACTERISTICS



INSTALLATIONS

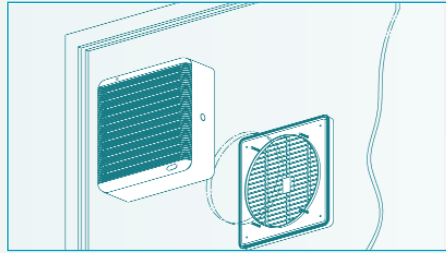
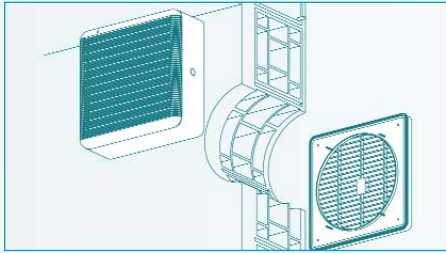

WIRING DIAGRAMS

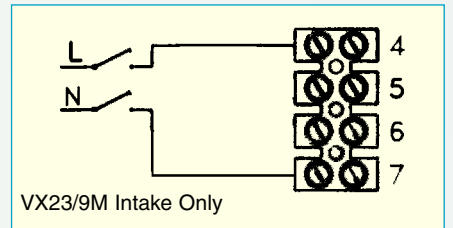
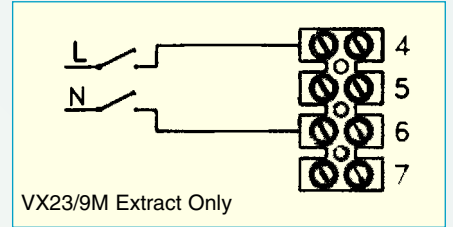
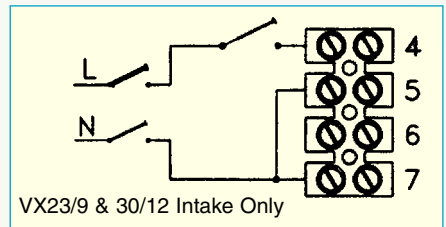
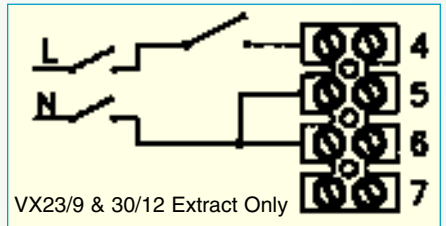
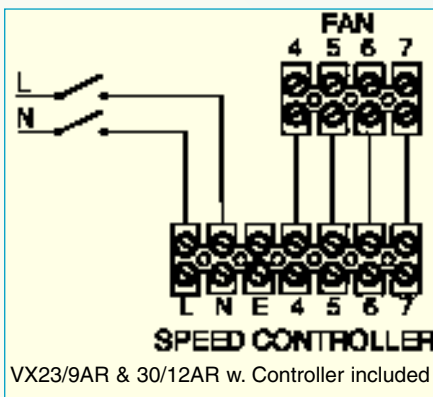
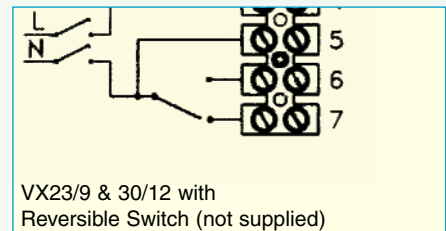
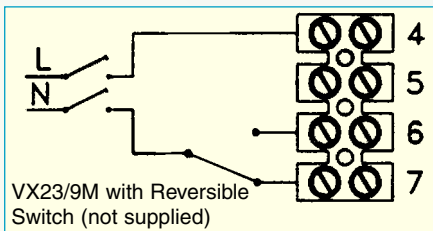
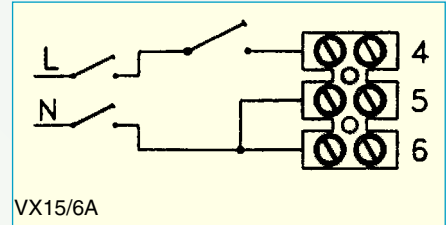
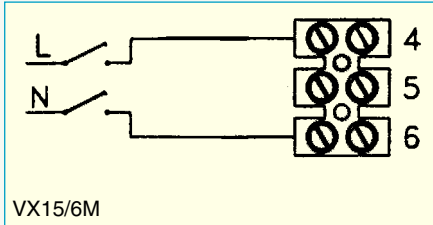

DIMENSIONS

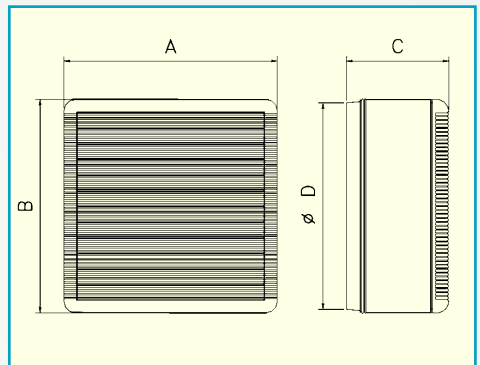

	A	B	C	D
VX15/6s	195	195	126	184-188
VX23/9s	287	287	138	254-258
VX30/12s	364	364	162	324-329

PRESSURE

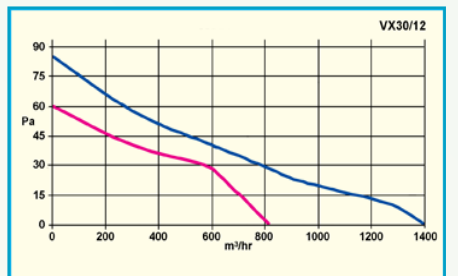
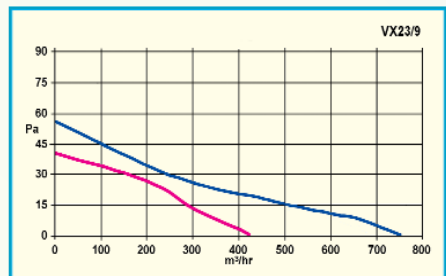
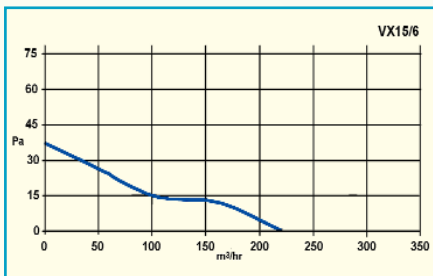

TECHNICAL DATA

Model	max m³/hr	max litres/sec	min m³/hr	min litres/sec	Volts	Hz	Max Watts	Max dbA	Weight kg
VX15/6s	220	61	-	-	230	50	20	40	1.7
VX23/9s	750	208	400	111	230	50	42	50	3.4
VX30/12s	1,400	389	800	222	230	50	102	56	4.6

FULL RANGE OF ACCESSORIES AVAILABLE INCLUDING FLEXIBLE AND FLAT DUCTING

Tel: +44(0)1494 522333
Fax: +44(0)1494 522337

Vectaire Ltd
Lincoln Road, Cressex Business Park
High Wycombe, Buckinghamshire, HP12 3RH

Email: sales@vectaire.co.uk
Web: www.vectaire.co.uk